

WHEELCHAIRS MANUALS - BASIC / TRIAL



Contents

- [1.- Important](#)
- [2.- Icons used on the label and in the manual](#)
- [3.- Product use](#)
- [4.- Product description](#)
- [5.- Warnings and safety](#)
- [6.- Assembly and use](#)
- [7.- Technical Specifications](#)
- [8.- Care and maintenance](#)
- [9.- Recycling the product](#)
- [10.- Storing the product](#)
- [11.- Useful life](#)
- [12.- Warranty and after-sales service](#)
- [13.- Tests and trials carried out](#)
- [14.- Manufacturer details](#)











1.- Important

Read the manual carefully before using this product and keep it in case of need.

If you cannot read or understand any warning, caution or instruction, contact the seller before using the product or you may be at risk of harm.

Consult your physician or orthopaedic specialist before use.

2.- Icons used on the label and in the manual

	Manufacturer details
	Date of manufacture
	Medical Device
	Observe safety instructions
	Maximum user weight in kg
	Declaration of Conformity
	Caution, danger of entrapment
	Check the user manual
	Product recycling information
	Recycling centre
SN	Product serial number
LOT	Product batch number
REF	Product reference or code

3.- Product use

Wheelchairs are aids that allow people to move about freely while seated without having to use the lower limbs.

4.- Product description



1. Seat
2. Backrest
3. Footrest
4. Footrest strap
5. Armrest
6. Front wheels
7. Rear wheels
8. Push rim
9. Parking brakes

Model identification

Model	Description
Basic R600	Lightweight manual wheelchair made of aluminium. 600 mm rear wheels
Reclining Basic	Lightweight manual wheelchair made of aluminium. Includes full reclining backrest and shifted back axle 600 mm rear wheels
Basic R300	Lightweight manual wheelchair made of aluminium. 300 mm rear wheels
Basic Duo	Lightweight manual wheelchair made of aluminium. 600 mm rear wheels and Duo system
Trial Standard	Lightweight active manual wheelchair made of aluminium. 600 mm pneumatic (inflatable) rear wheels with quick release
Trial Country	Active manual wheelchair, lightweight, made of aluminium. 600 mm pneumatic (inflatable) rear wheels with quick release. All-terrain front and rear wheels

Trial Beach	Active manual wheelchair, lightweight, made of aluminium. 600 mm pneumatic (inflatable) rear wheels with fixed axles. All-terrain front and rear wheels. All components susceptible to rust are made of stainless steel.
Resonance	Lightweight manual wheelchair made of aluminium. 600 mm rear wheels. Minimum quantity of metallic components.

5.- Warnings and safety



Failure to follow these safety precautions may result in serious injury.

- Do not exceed the maximum weight limit of 125 kg.
- Follow the folding and assembly instructions and ensure that all parts of the chair are securely fastened before use. You should take great care when using and travelling.
- Avoid leaning your body so much that you overbalance the chair, avoid sudden accelerations and braking, and do not go fast so that the wheelchair remains stable.
- Slow down when appropriate for the conditions (obstacles, wet surfaces, strong wind, tight spaces, etc.).
- Care is particularly required when tackling ramps, curbs and changes of level. Ramps must be wide enough for safe passage. Do not go up or down a slope steeper than 12° alone, it could be dangerous. The surface of the slope should be firm and non-slip. You can go up and down curbs with the help of someone else.
- Stairs are an insurmountable and very dangerous obstacle for wheelchair users. If there are no alternative routes to the stairs, such as ramps, lifts or platform lifts, navigate the stairs with the help of one or more other people. They should hold the chair by its fixed, non-detachable parts.
- The minimum dimensions for wheelchair use of lifts are:
- Usable depth > 1200 mm - Usable width > 900 mm - Clearance between doors > 800 mm - Surface area > 1.5 m²
- Uneven surfaces such as broken road surfaces, gravel, grass, sand, mud or decking are difficult to navigate in a wheelchair and can even cause falls.
- For safety during any transfer, apply the parking brakes.
- Do not hang anything on the back of the chair or on the handles, which could cause the chair to tip over.
- After making any adjustment to the chair, we recommend checking all the screws of the chair. It is reasonable to expect that just from everyday use, the screws and nuts may come loose. If they have done, contact your dealer.
- The brakes are intended for use as parking brakes and not to slow down or stop the chair in motion. Forta accepts no liability for the consequences of any improper use.
- All detachable components must be assembled with care to avoid injury or damage to the wheelchair.
- Make sure that the wheelchair is fully unfolded and that the detachable components are fixed in place and correctly positioned before use.
- To go up or down steps, pavements, etc., the wheelchair must be fully open and the feet on the right rests.
- The wheelchair is not suitable for use as a seat in a motor vehicle.
- In the case of wheelchairs with pneumatic tyres, you should regularly check the pressure in the tyres. We recommend checking every week.
- Make sure all parts are securely fastened and in good working order before using the wheelchair.
- Replace any wheelchair components that are worn or damaged.
- Test the parking brakes on the wheels before using the wheelchair. When the wheels are locked the brake shoe should stop the wheels turning.
- When the parking brakes are released the wheels should be able to turn freely
- Only use accessories and parts supplied by Forta.
- Do not adjust the wheelchair while it is in use.
- Do not use the wheelchair on wet, icy or snowy inclines.
- Keep the wheelchair clean and in perfect condition.
- All wheelchairs contain or may contain plastic parts that can produce toxic gases if burned. Do not expose the wheelchair or any of its components to intense heat that

could make it or them catch fire.

- Pool water, sand and sea water contain chlorine and other chemicals that will damage the wheelchair, internal bearings and fixings. If the wheelchair is exposed to any of those hazards, vulnerable components should be lubricated with oil and vaseline (spray) and the wheelchair should be washed.
- We recommend regular checks of the tightness of screws because they may come loose in everyday use.

Safety precautions for specific models:

BASIC DUO

- Only use the 250 mm wheels inside and for short distances and narrow passages.
- When operating the Duo system, take care not to let clothing or body parts become trapped.

TRIAL BEACH

- When the wheelchair is taken into the water with a person in it, a second person must always be present because the wheelchair could be pushed over by a wave and the wheelchair user would be at risk of harm.
- The wheelchair must be maintained each time it is taken into the water (as described in section "8. Maintenance"). Failure to carry out that maintenance will lead to irreparable damage to the wheelchair, for which Forta accepts no liability.

6.- Assembly and use

Assembly and folding

The wheelchair does not need to be assembled before use except for the footrests, which are shipped unattached to the wheelchair. No tools are required for the assembly of the footrests and armrests.

1. The footrests are mounted by placing them on the guides of the frame, pressing towards the outside of the wheelchair and sliding the rests until they are at the required height. Release the lock and the footrest will remain fixed in position. The footrest can also be turned inwards or outwards by pulling it up to the top of the guide.
2. To attach the armrests, simply place them on their guides and gently push downwards to snap them into place.
3. To remove the armrests, reverse the process. Press the unlocking lever before pulling upwards.



Depending on the model, your wheelchair will have front or back folding. For front folding, there is a folding lever at the front and for back folding the lever is at the back of the

wheelchair. In both cases, the lever is under the seat. To fold and unfold the wheelchair, follow the instructions below:

1. For front folding, pull the lever upwards and push it outwards (towards the footrests) to fold. To open the wheelchair, simply push the lever in towards the wheelchair until it locks.
2. For back folding, pull the lever down and push it outwards (towards the pedal and the back of the wheelchair) to fold. To open the wheelchair, simply push the lever in towards the wheelchair until it locks.

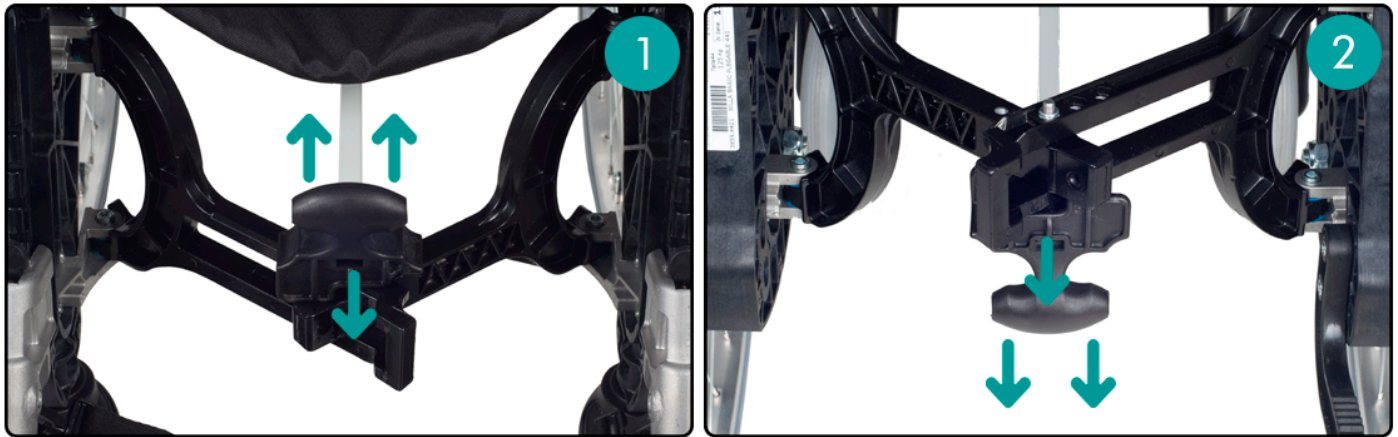

Always check that the wheelchair is fully open and the latch is in the locked position before using it.

1. Front folding lock
2. Back folding lock



The folding manoeuvre can be performed while someone is sitting in the wheelchair to make it as narrow as the person's hips. The wheelchair should only be made more narrow to pass through tight spaces and only on flat surfaces.

User adaptation

Users of lightweight manual chairs should consider three very important things when choosing a chair.

First, the height and weight of the intended user, i.e. a wheelchair must always fit its user. Second, be clear what you are going to do in the wheelchair (transfers, folding, etc.). Finally, what is the environment in which the wheelchair is going to be used like.

The table makes recommendations that should be taken into account when choosing a wheelchair to meet the needs of a particular user:

USER MEASUREMENT	RELATED TO	WHEELCHAIR MEASUREMENT
Arm length	Push rim reach	Angle between arm and forearm 120° when holding the push rim

Head-to-floor height	Sight distance	
Height elbows-floor	Armrests height	20mm above elbow with arms extended
Knee height	Footrest-to-seat distance	Footrest height 100-130mm
Distance buttock-back of knee	Distance footrest-seat	Seat Clearance of 25mm between thighs and side of armrest
Leg length	Seat depth	30-50mm between the seat and the back of the knee
Hip width	Seat width	Clearance of 25mm between thighs and side of arm rest
Knee angle	Seat and footrest tilt	Seat tilt 1-4° backwards
Distance armpit-outside of hip	Backrest height	Backrest 25 mm below the shoulder blade
Approximate weight	Wheelchair resistance	Maximum user weight of 140 kg

Using the wheelchair

This section provides basic recommendations for use of the wheelchair by the person using it and any companion:

- Before using the wheelchair, check that it is correctly positioned and that all parts are unfolded and securely fastened.
- To reach towards and pick up any object, point the front casters towards the object. Before moving your body to reach an object, apply the parking brakes to make the wheelchair stable.
- The wheelchair must be driven or propelled safely and efficiently. The seat must be set at a height that allows the user to grip the push rim with an angle between the arm and the forearm of about 120°. The backrest should be tilted slightly backwards.
- It is important to maintain a steady pace to reduce fatigue as much as possible. If you want to go faster, you should make each push shorter and push with greater frequency, bearing in mind that short pushes increase stability and long strokes give more impetus.
- We recommend slowing down by holding the push rims and slowing down gradually until the wheelchair comes to a stop. The parking brakes should not be used for braking while moving. It could be dangerous.
- To turn, grip the push rim with one hand and push it backwards, and push the other rim forwards with the other hand. The further each hand moves, the sharper the turn.
- The unoccupied wheelchair can be transported by vehicles and by air.

Use of the Folding Backrest and Reclining Backrest

The Reclining Basic model includes the option to recline the backrest backward. Additionally, there is a folding backrest option available for other Basic models, which allows the backrest to fold forward to reduce the space the wheelchair occupies. Both systems operate in the same way.

To enable the backrest movement and position it as desired, locate the handles situated at its base, where the backrest tubes connect with the wheelchair chassis. Position these handles perpendicular to the tube, unlocking the system. Once unlocked, adjust the backrest to the desired position and then push each handle back to its original position, locking the backrest. Make sure the backrest is completely locked before using the wheelchair.

Use of the Duo system

The Duo Line model has 600 mm and 250 mm rear wheels. The quick release axles mean that the wheels are interchangeable.

1. Duo wheels on the outside
2. Duo wheels on the inside



Transit brakes are available for the Duo system as an optional accessory. The transit brakes allow the 250 mm wheels to be locked to stop the wheelchair moving when the 250 mm wheels are in use. Activate the brakes to stop the wheelchair moving, whether with the 250 mm wheels are on the outside or the inside.

Use of the attendant brakes option

The attendant brakes allow the wheelchair to be stopped safely and conveniently by a companion.

Warning: Brakes should only be installed by operatives authorised by Forta.

Press the trigger on each of the wheelchair's handles to operate the brakes. To lock the brakes and leave them on, push the red component on the front of the lever.



Use of the Trial Beach wheelchair



The Trial Beach chair can be taken into the water and manoeuvred in the same way as on a normal surface. Thanks to its polymer and aluminium construction, it is buoyed by the water rather than sinking, making it easy to manoeuvre. It can also move along the beach and areas where a normal chair would get bogged down.

7.- Technical Specifications

The measurements and weights stated in this manual are for the standard wheelchair and may vary for a wheelchair with accessories or options. Changing wheels or making modifications may mean that the wheelchair does not comply with its type approval.

- Tolerance for measurements in this manual: ± 10 mm
- Weight tolerance: ± 0.5 kg
- Tolerance for inclines: $\pm 2^\circ$
- Seat tilt: 3°
- Backrest tilt: 93°
- Maximum user weight capacity: 140 kg
- Seat materials: Polyester/Nylon

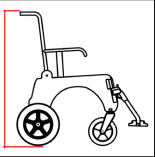
The specific measurements for each of the model in the wheelchair range are set out below. All measurements are in millimetres (mm) except for weight which is in kilograms (kg). Units not shown in the table for ease of reading and lack of space.

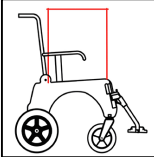
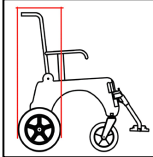
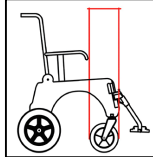
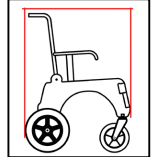
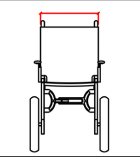
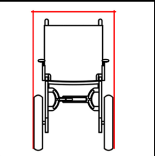
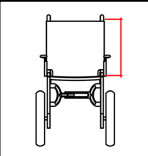
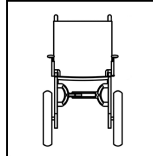
A	B	C	D	E	F	G	H
							
Height	Length	Seat height	Seat depth	Rear wheel diameter	Front wheel diameter	Length without footrests	Seat width
I	J	K					
							
Width	Backrest fabric height	Weight					

Basic R600			
Size	41	44	46
A	930	930	930
B	1110	1110	1110
C	495	495	495
D	430	430	430
E	600	600	600
F	200	200	200
G	810	810	810
H	410	440	460
I	590	620	640
J	400	400	400
K	13,85	13,92	14,12

Basic R300

Size	41	44	46
A	930	930	930
B	990	990	990
C	495	495	495
D	430	430	430
E	300	300	300
F	200	200	200
G	700	700	700
H	410	440	460
I	570	600	620
J	400	400	400
K	12,21	12,28	12,48

Basic Duo			
Size	41	44	46
A	930	930	930
B	1110	1110	1110
C	495	495	495
D	430	430	430
E	600	600	600
F	200	200	200
G	810	810	810
H	410	440	460
I	590	620	640
J	400	400	400
K	16,25	16,32	16,52

Trial Standard			
Size	41	44	46
A	895	895	895
B	1000	1000	1000
C	500	500	500
D	430	430	430
E	600	600	600
F	150	150	150
G	800	800	800
H	410	440	460
I	590	620	640
J	400	400	400
K	13,85	13,92	14,12

Trial Country / Trial Beach			
Size	41	44	46
A	810	810	810
B	1000	1000	1000
C	520	520	520
D	430	430	430
E	600	600	600
F	200	200	200
G	810	810	810

H	410	440	460
I	590	620	640
J	400	400	400
K	14,71	14,78	14,98

8.- Care and maintenance



If the product is not cared for and maintained in perfect condition, there will be a risk of accident.

Regular preventive maintenance allows you to keep your wheelchair in optimal working condition and to detect and solve small problems that could develop into major failures over time. Not only does it improve day-to-day safety, but it also saves time and money in the long run.

Note: In the event of a breakdown, any repair should be carried out by a specialist provider (orthopaedics).

General recommendations

Some of the most frequent maintenance and care for your wheelchair are described below:

- Keeping the wheelchair clean and in perfect condition will enhance its performance and appearance.
- We recommend using bicycle cleaning and maintenance products like lubricating oils, spray cans, damp cloths, etc.
- If the chair has been exposed to water from rain, shower, etc., we recommend drying it with a cloth. Spray some bicycle oil on a cloth and apply it to the joints and axles.
- To wash the fabrics, use neutral soap at a maximum temperature of 30°C. Do not iron or spin-dry.
- Check the crosshead union nut, if it is loose, tighten with wrench or spanner.

ACTION	FREQUENCY
Unfolding of the chair and its accessories	Daily
Checking of nuts and bolts	Weekly
Inflatable wheels	Weekly
Condition of push rims	Weekly
Brake condition	Daily
Cleaning	Daily
Presence of cracks	Weekly
Lubrication	Weekly
Upholstery condition	Weekly
Disassembly mechanism	Monthly
Adjustable components	Monthly
Bearings	Monthly

Specific maintenance of the Trial Beach wheelchair

Swimming pool water contains chlorine and other chemicals which, like sand and salt water from the sea, will damage the chair beyond repair and destroy the internal bearing balls and hardware, so here are the procedures to follow.

When you have finished in the sea, the wheelchair should be thoroughly rinsed with fresh water, with particular attention to the folding mechanism and footrests. As you rinse, open and close them to ensure there is no water, sand or anything else left from the sea or the pool.

After thoroughly rinsing the wheelchair, dry it with a cloth and lubricate all moving parts such as bearings, folding systems, etc., and metal parts (screws, etc.) with oil and vaseline (spray).

Do not clean the chair with products containing soaps. They contain soda which corrodes the aluminium.

Some components may rust if not properly cleaned and protected. Rust caused by improper use, maintenance and/or storage is not covered by the warranty.

9.- Recycling the product



When the product has become unusable and requires disposal, contact your specialist dealer. If you want to recycle it yourself, ask your local waste management company or nearest recycling centre for advice on disposal.

10.- Storing the product



If not correctly stored, the product may be damaged leading to the risk of an accident.

- Do not store this product for an extended period of time near a heat source or in the sun (e.g. in front of a window or near a radiator) or near a cold source.
- Keep the product away from flames and sparks.
- Store the product as follows:
 - Store the product in a dry, cool place.
 - Protect the product from dust and rust by packaging or bagging it.
 - Store all removed parts or components together in one place so they do not get mixed up with anything else or get lost.
 - Do not place any weight on any components (do not place heavy objects on the product or any component).

11.- Useful life

The expected useful life of the product is 1 year in normal conditions of use, safety and maintenance. After that time, the product can be used as long while it remains in perfect conditions of use and maintenance. Some parts or components may in any event have to be replaced due to normal wear and tear within less than this time.

12.- Warranty and after-sales service

Warranty terms and conditions:

Only original Forta products purchased from authorised dealers are covered by the warranty against defects in parts and workmanship.

The warranty runs from the date of purchase for 3 years for structure and components subject to the following conditions:

- Only original FORTA products purchased from authorised dealers will be covered by the warranty against defects in parts and workmanship.
- The purchasing establishment must give notice of any defect in the product immediately.
- The manufacturer will not have any liability for defects caused by improper handling, negligence or failure to follow the instructions set out in this manual.
- During the warranty period, any part that proves defective due to faulty assembly or materials will be repaired or replaced free of charge by Forta.
- The warranty will be absolutely void if incorrect modifications or adjustments are made to the product or if parts or options not supplied for the product model are fitted.
- Damage from rust caused by misuse or negligence or the action of any liquid or gas that may damage the product are excluded from the warranty.

THE WARRANTY DOES NOT COVER THE CONSEQUENCES OF ANY TRAVEL PROBLEM, IN PARTICULAR ISSUES RELATING TO TRANSPORT, LOSS OF PROFIT, EXPENSES, ETC.

Forta will have NO liability in the following circumstances:

- Normal wear and tear of the product or inappropriate or incorrect use.
- Defects in any assembly or repair carried out by the purchaser or a third party.
- Negligent handling or maintenance or use of unsuitable parts.
- Repairs or modifications carried out in non-official workshops.
- Forta will have no liability for any harm or loss suffered by the user or any third party as a result of any modification to or alteration of any product.
- The warranty also excludes modifications made other than with original Forta parts.

The warranty certificate must be sent to FORTA, S.L. together with a photocopy of the purchase invoice within 15 days from the date of purchase. To validate the warranty, the user must submit the warranty certificate bearing the stamp the seal of the outlet that sold the product. You can download the warranty certificate here: www.fortas.es/en/manuales/doc/GARANTIA_CONTRACTUAL.pdf.

13.- Tests and trials carried out

FORTA products comply with Annex IV to MDR (EU) 2017/745, are CE marked and have been designed and tested in accordance with UNE-EN 12183:2023. Forta is obliged to certify compliance by its products with a number of essential requirements. There is a standard that specifies the inspection and testing methods to show compliance of the products with those requirements. The standards that the product complies with are listed below:

Brief description of relevant law	Current law
Information provided by the manufacturer	UNE-EN ISO 20417:2021
Quality management system	UNE-EN ISO 13485:2018
Risk management	UNE-EN ISO 14971:2020
Testing of medical devices and manual wheelchairs	UNE-EN ISO 21856:2023 UNE-EN 12183:2023
Biological assessment of medical devices	UNE-EN ISO 10993-1:2021
Fire resistance testing	UNE-EN 1021-1:2015 UNE-EN 1021-2:2015
Maximum load	125 kg

14.- Manufacturer details

FORTA - FABRICACIONES ORTOPÉDICAS ALBACETE, S.L.

Pq. Emp. Campollano, c/C 90 Nave 1

02007 Albacete

España - Spain

info@fortasl.es

www.fortasl.es



MADE IN EUROPE

